

BARTCO LIGHTING

5761 Research Drive Huntington Beach, CA 92649

Installation and Assembly Instructions

BSS210-X CABLE MOUNT

WARNING: RISK OF FIRE OR ELECTRICAL SHOCK

THIS PRODUCT MUST BE INSTALLED IN ACCORDANCE WITH THE APPLICABLE INSTALLATION CODE BY A PERSON FAMILIAR WITH THE CONSTRUCTION AND OPERATION OF THE PRODUCT AND THE HAZARDS INVOLVED

Warning: To avoid possible risk of fire or shock, turn off power prior to installation, maintenance or lamp replacement preferably at the circuit breaker.

Verify the existing Input Voltage and select matching voltage accordingly before wiring. Install per local and the National Electrical Code.

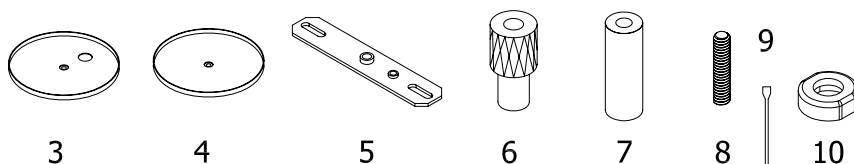
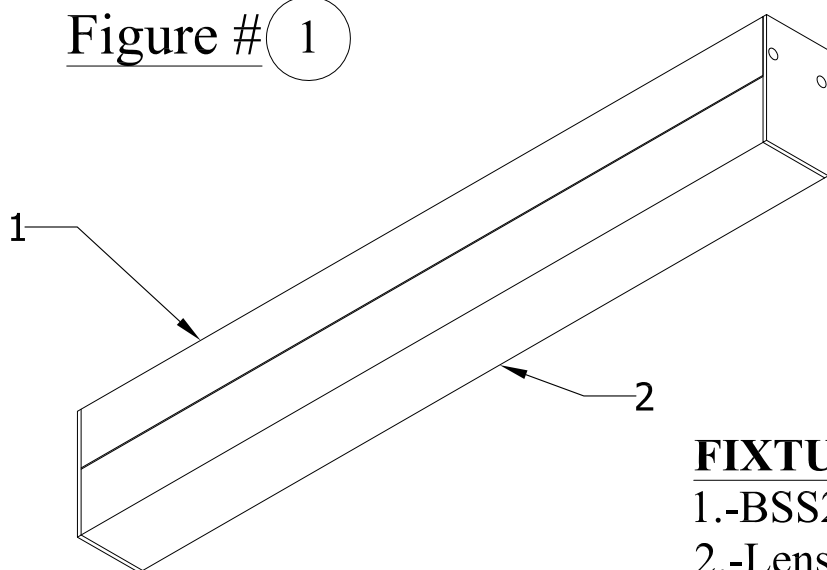

Figure # 1



FIXTURE ARTICLES:

- 1.-BSS210-X-SM
- 2.-Lens
- 3.-White canopy with power feed x1
- 4.-White canopy without power feed x1
- 5.-Junction box bracket with ground screw x2
- 6.-Cable coupler for power canopy x1
- 7.-Cable coupler for no power canopy x1
- 8.-1/4 STUD x2
- 9.-Suspension cable x2
- 10.-Strain relief x2

Fixture preparation:

- Remove the components of the packaging box
- Identify components: Sizes may vary per customer.
- The box must contain the following articles (see Figure #1)

INSTALLATION INSTRUCTIONS FOR CANOPY

- Install cable through the cable canopy feed (included in kit). There will be two different kits one for the power side of the fixture and one without a power entry. (see figure # 2)

Figure # 2

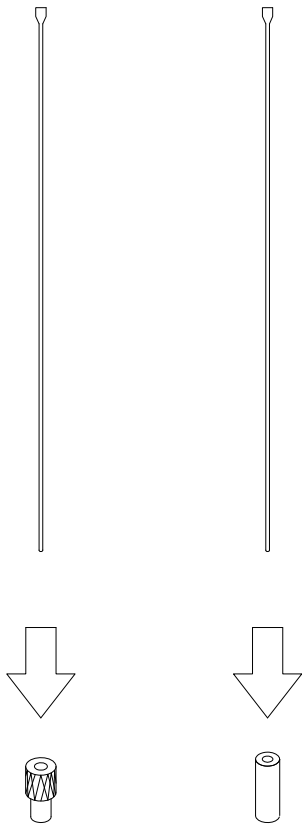

Figure # 2A

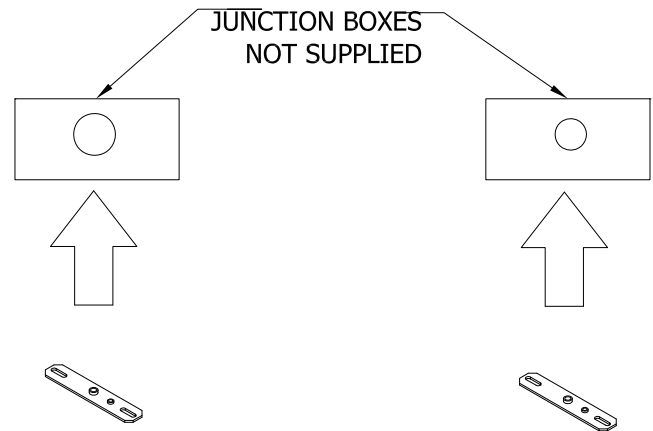

Figure # 2B

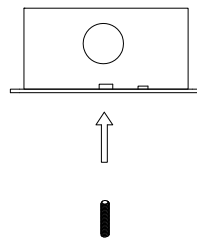
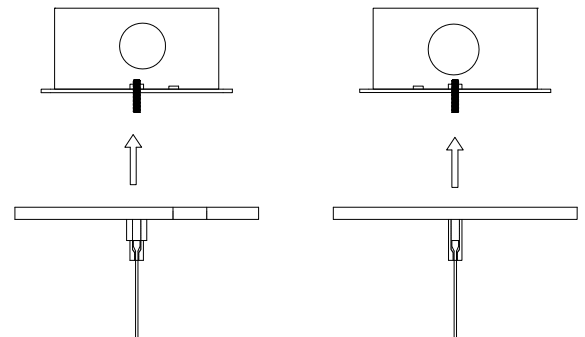

Figure # 2C



- Install the canopy bracket into the junction boxes (if multiple) before installing canopy cover. (See Figure # 2a)
- Install the $\frac{1}{4}$ stud into both canopy brackets before installing canopy. (See Figure #2b)
- Then install both of the cable couplers with its own canopy cover into canopy bracket. (See Figure #2c)
- Canopy assembly should be complete. (See Figure #3)

- Take fixture and install cable into cable grippers on the base of the fixture.(See Figure #3)

Figure # 3

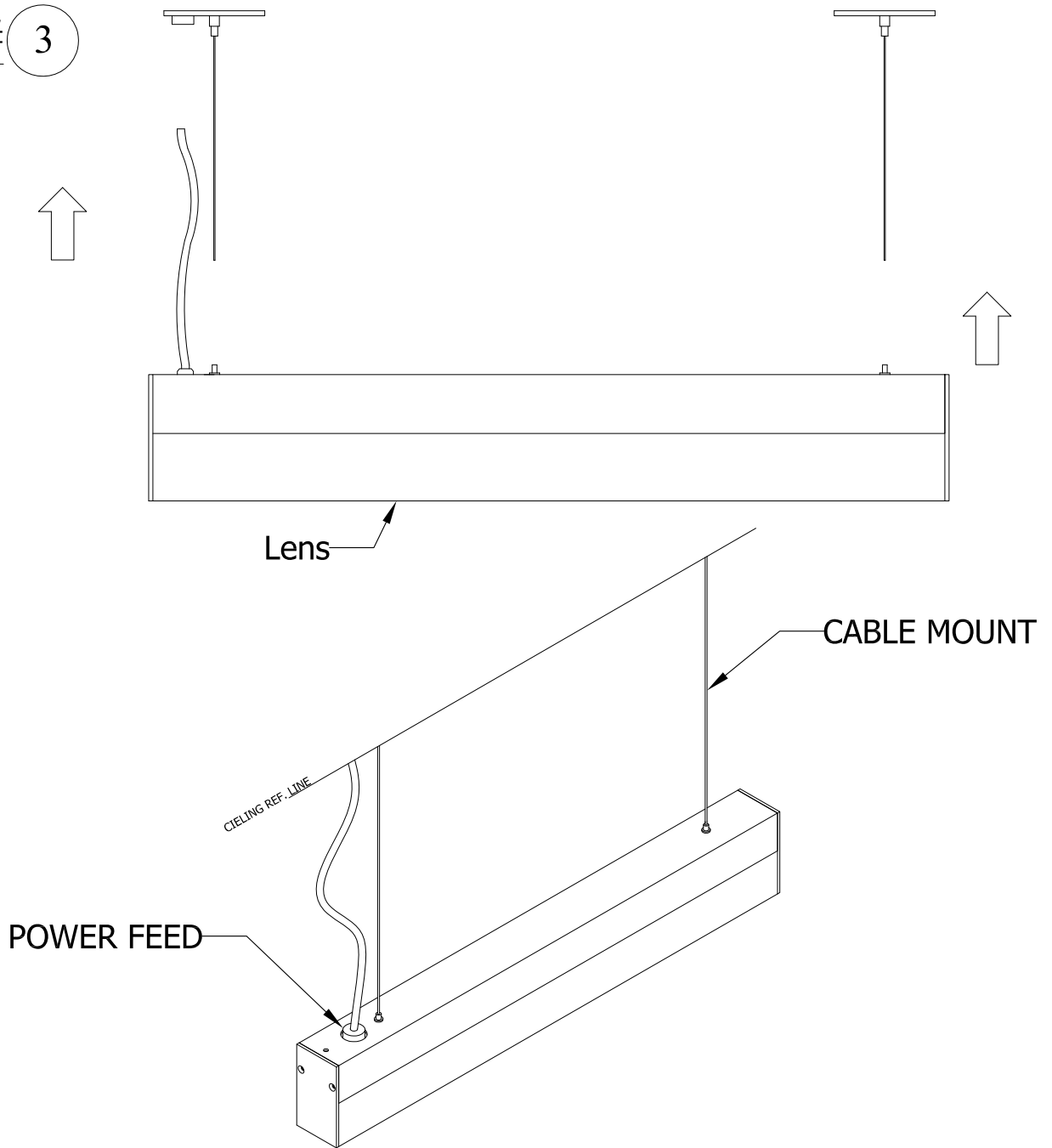

- Clean and wipe off any dirt or finger prints and fixture is complete.