

Type:

BSS110

Cove mount adjustable LED fixture



- Fully assembled wiring channel is formed and welded 20 ga. steel chemically treated to resist corrosion and enhance paint adhesion with extruded aluminum LED housing in powdercoat white finish
- Frosted acrylic lens available with 15° and 120° beam angles
- LEDs are available in 2,700K, 3,000K, 3500K, 4,000K and 5,000K (±200K) color temperatures
- Driver has 24V ±5% output voltage. 120-277 VAC. input, 0-10V (100-10%) dimming
- Smooth 90° rotatable and hold at any fixed angle
- Lamp life is rated at 50,000 hours
- Limited 3 year warranty
- UL listed for dry and damp locations
- IBEW manufactured and labeled
- Made in the U.S.A.

	LENGTH		COLOR TEMPERATURE		DRIVER OPTION		VOLTAGE		BEAM ANGLE
BSS110	+		+		+		+		
	<ul style="list-style-type: none"> 2: 23" 3: 34-1/4" 4: 45-1/2" 		<ul style="list-style-type: none"> 27: 2700K 30: 3000K 35: 3500K 40: 4000K 50: 5000K 		<ul style="list-style-type: none"> DIM: dimming leave blank for non-dimming 		<ul style="list-style-type: none"> U: 120V-277V 		<ul style="list-style-type: none"> N: 15° W: 120°

Profile

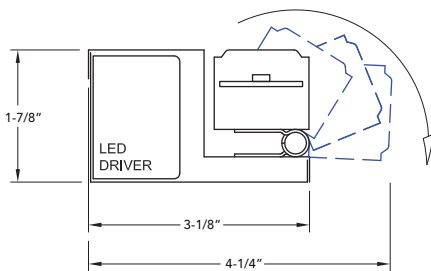

Isometric

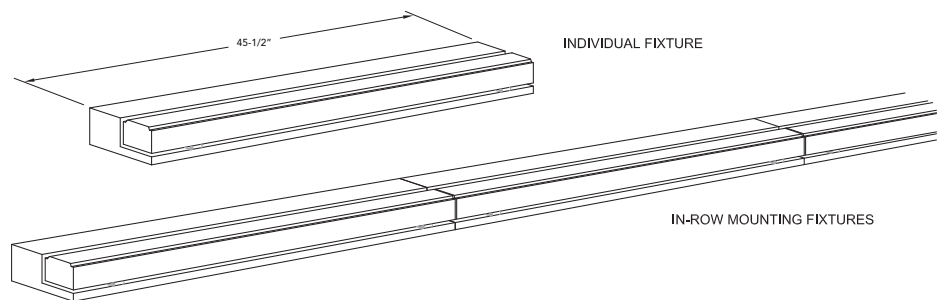

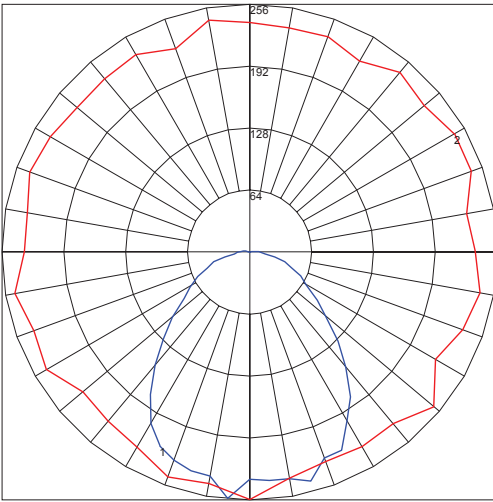

Maximun Candela = 255.9 Located at horizontal angle = 270 Vertical angle = 5
#1 - Vertical plane through horizontal angles (270 - 90) (through max. cd.)
#2 - Horizontal cone through vertical angle (5) (through max. cd.)